

Front part of the pizza ovens, including door, made of stainless steel. All ovens with separate control for each chamber, refractory stones on the lower part of the chamber. The models are divided into one-chamber and two-chamber ones. If necessary it is possible to order stands for the ovens.



- Visible part of the chamber from AISI 430
- Casing and back part from galvanised varnished sheet
- Door together with the front panel
- Inner part of the door from stainless steel
- Two handles on the door
- Main switch and switch for inner lightning for each chamber
- Two thermostats for each chamber
- Front part of the chamber from AISI 430
- Chamber made of aluminium
- Controllable chimney for humidity regulation
- Refractory stones on the lower part with thickness 14 mm
- Possibility of two ovens on each other



Index	Model	mm	kg	V / Hz	°C	kW	mm internal
104 200 400	E 4	980 x 909 x 412	54,2	400 / 3N / 50-60	50 - 450	4,8	700 x 700 x 150
104 200 600	E 6	980 x 1259 x 412	93,8	400 / 3N / 50-60	50 - 450	7,2	700 x 1050 x 150
104 200 650	E 6 L	1310 x 894 x 412	92,5	400 / 3N / 50-60	50 - 450	8	1050 x 700 x 150
104 200 900	E 9	1310 x 1253 x 412	109	400 / 3N / 50-60	50 - 450	12	1050 x 1050 x 150
104 200 800	E 8	980 x 905 x 763	128,5	400 / 3N / 50-60	50 - 450	9,6	2 x 700 x 700 x 150
104 201 200	E 12	980 x 1259 x 763	155,7	400 / 3N / 50-60	50 - 450	14,4	2 x 700 x 1050 x 150
104 201 250	E 12 L	1310 x 912 x 763	169,1	400 / 3N / 50-60	50 - 450	16	2 x 1050 x 700 x 150
104 201 800	E 18	1310 x 1266 x 763	205,9	400 / 3N / 50-60	50 - 450	24	2 x 1050 x 1050 x 150
118 060 078	E 4/50	830 x 665 x 412	39	400 / 3N / 50-60	50 - 450	4	550 x 550 x 150
118 060 082	E 8/50	830 x 665 x 763	78	400 / 3N / 50-60	50 - 450	8	2 x 550 x 550 x 150

E 4

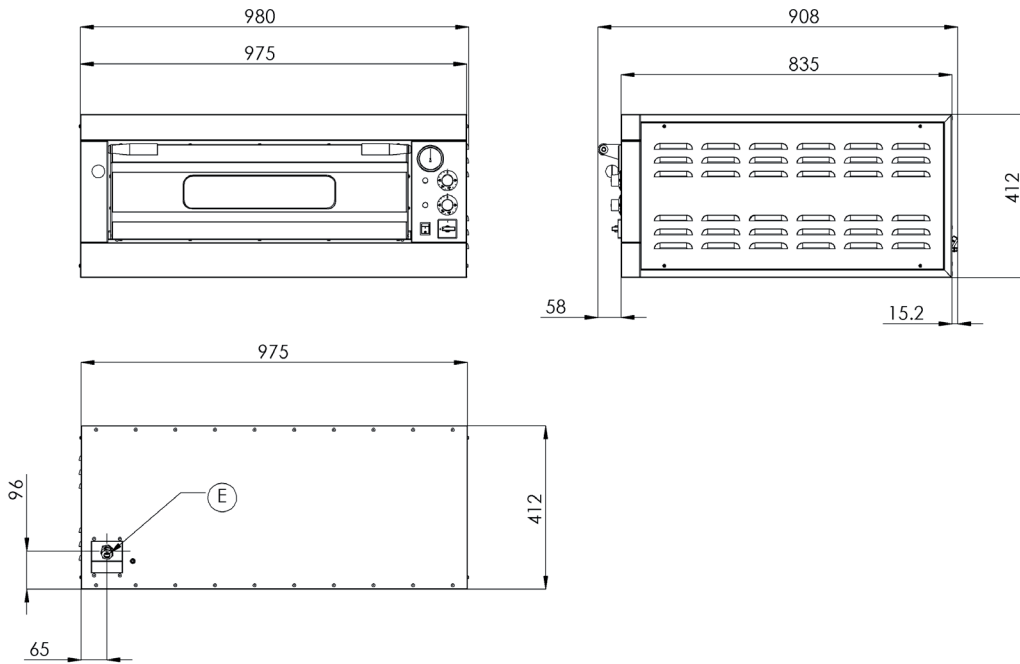

E 6

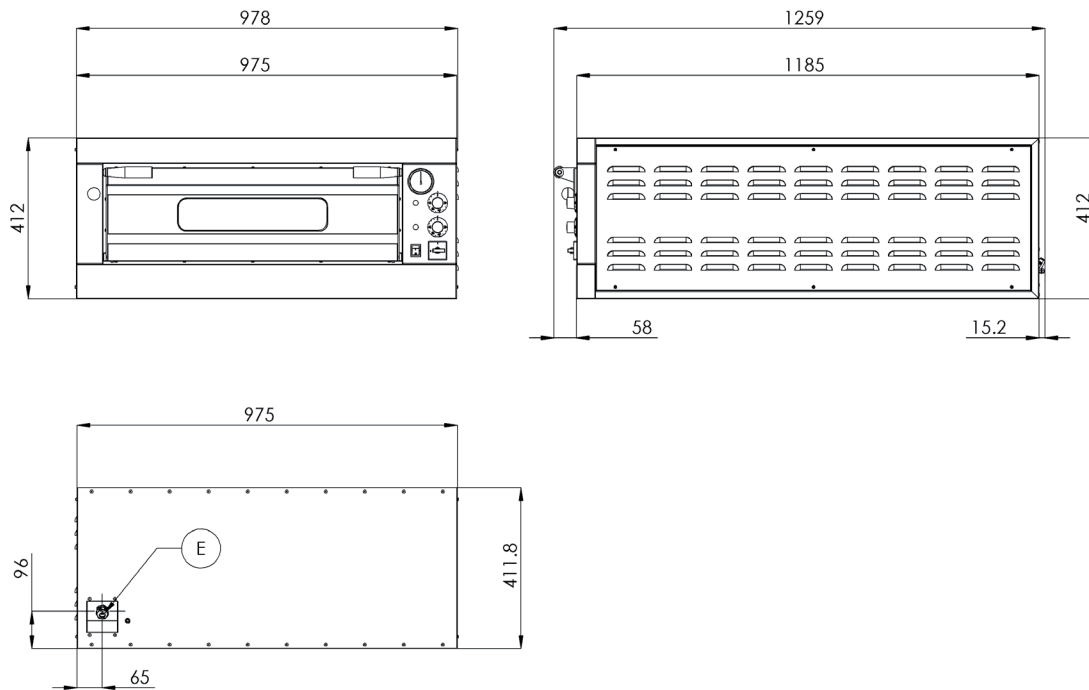

E - electric

E 6L

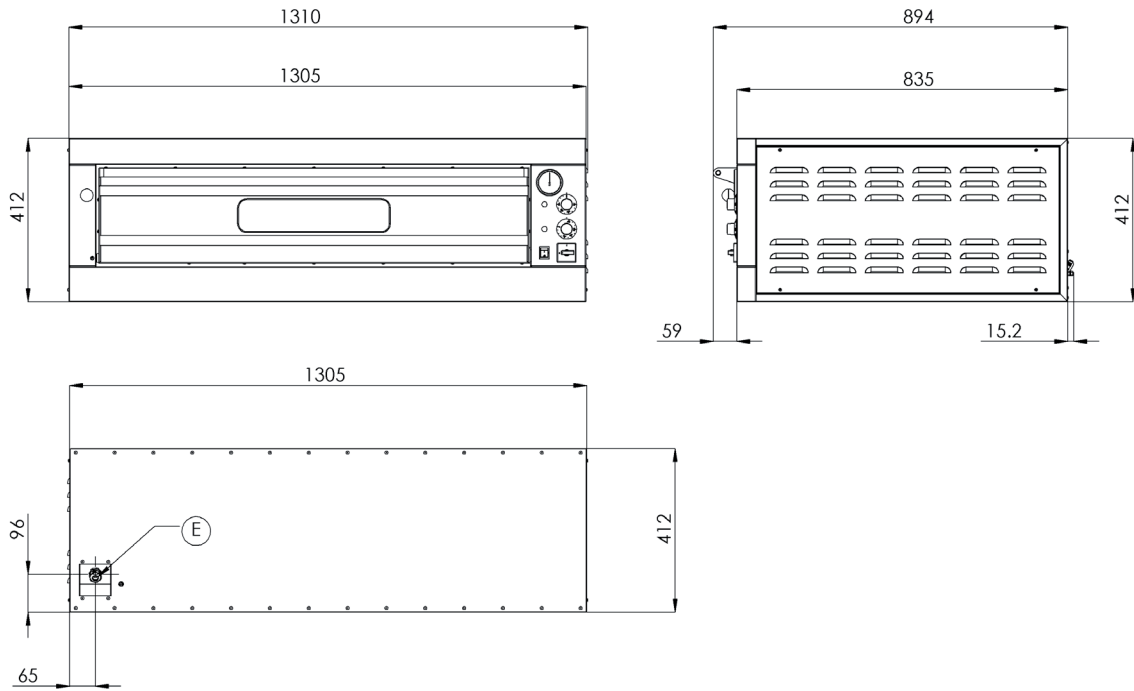

E 9

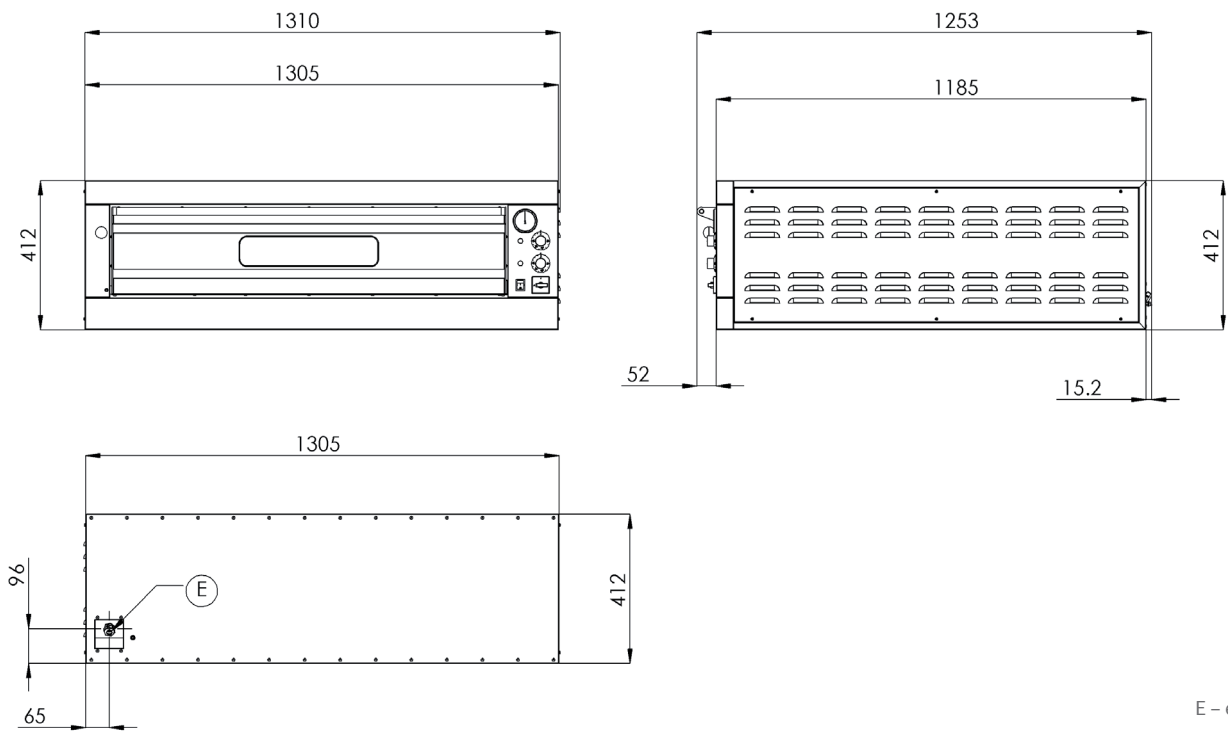

E - electric

E 8

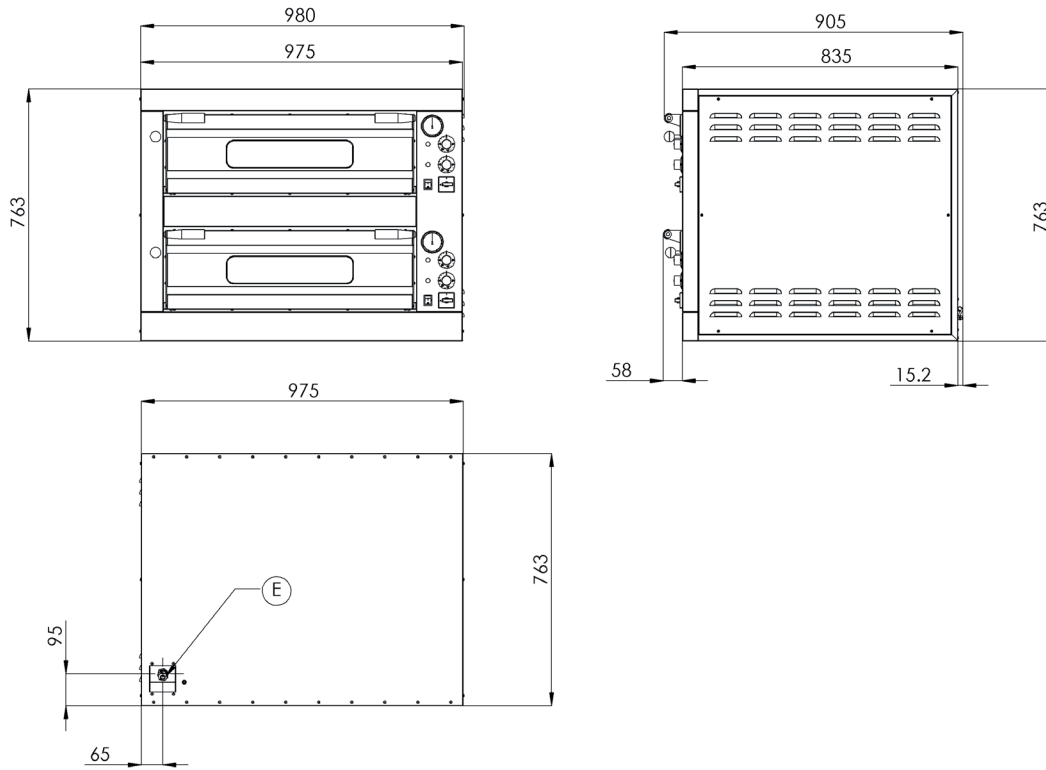

E 12

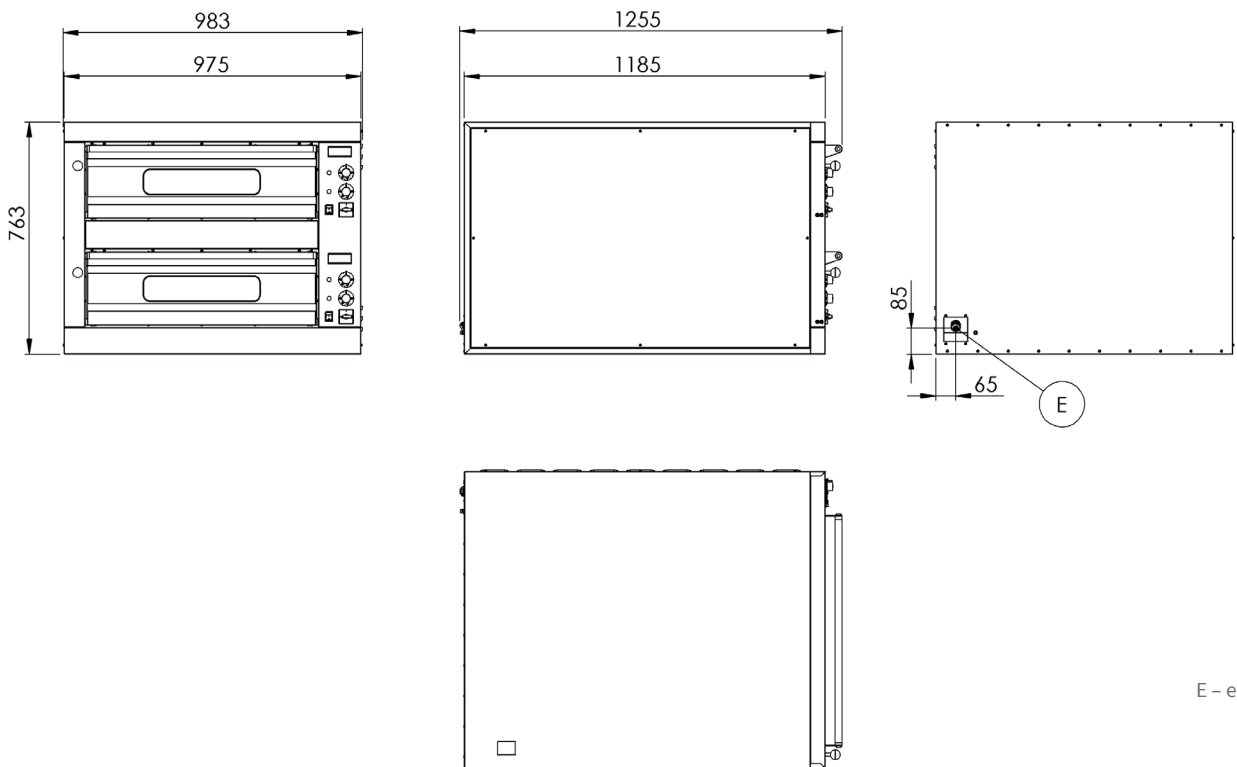

E - electric

E 12L

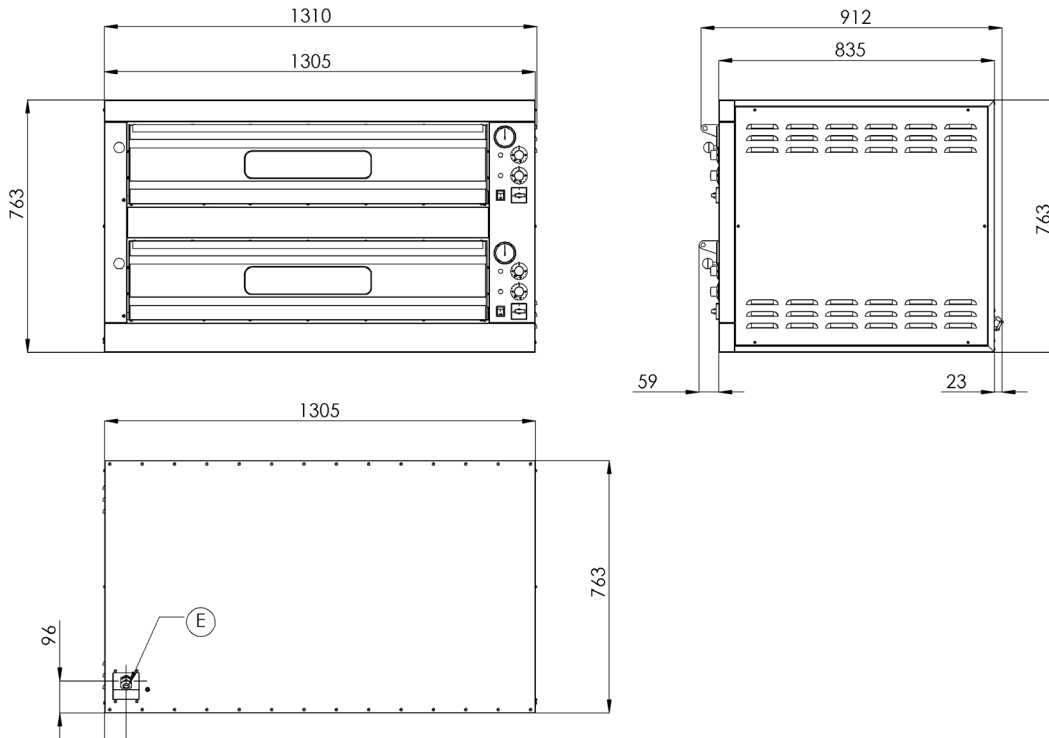

E 18

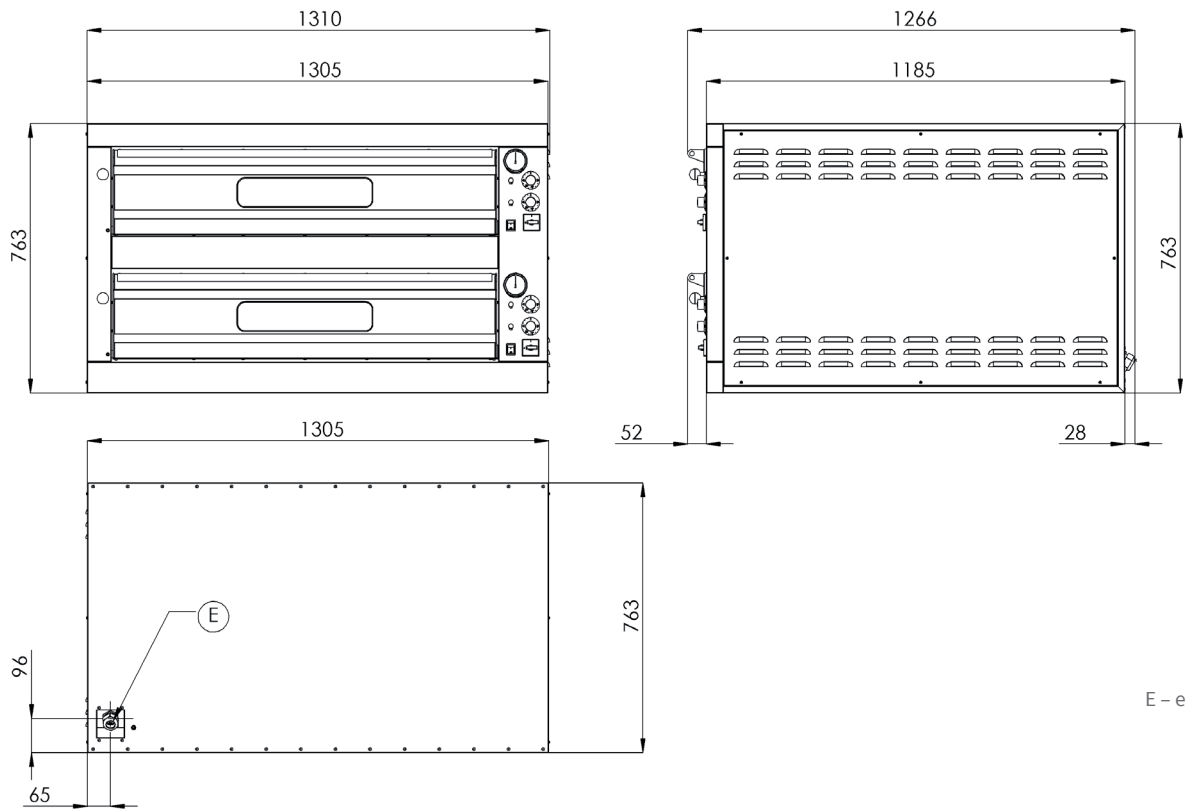

E - electric

E 4/50

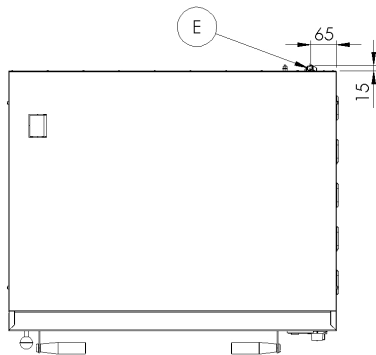
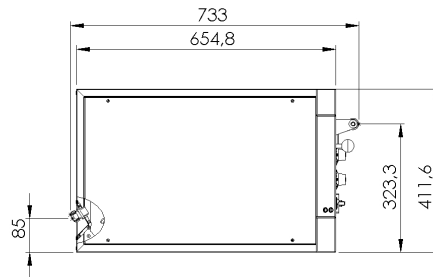
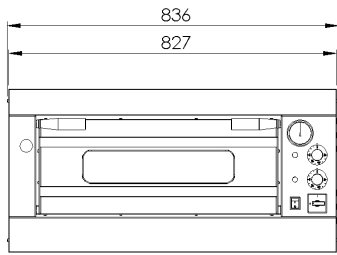

E 8/50

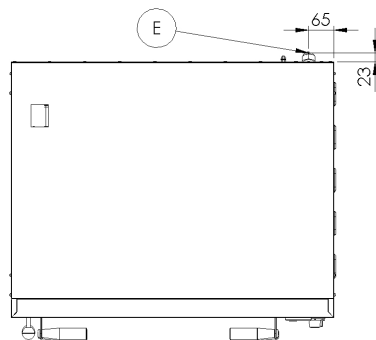
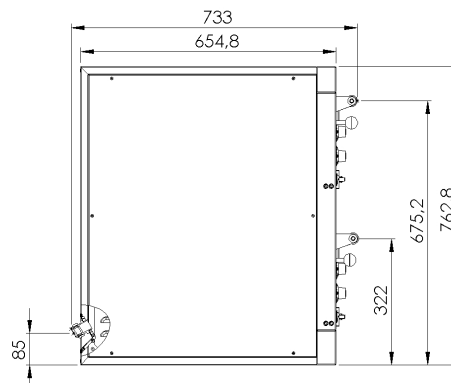
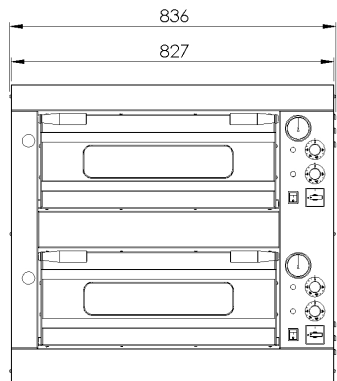

E - electric