

Snack units are made of AISI 430 stainless steel with AISI 304 top plate. All snack units include pressed top plate or basins with round internal angles and ergonomic front panels. All connection points are located on the device rear side. Wide selection of models and options helps in setting up a compact customized configuration.



- One and two deck models
- The option of two widths for one and two deck models
- Control by means of switch.
- Single deck module contains 4 units
- Two deck module contains 6 units
- Quartz unit with fast heat rise time
- The option to switch combinations of lower and upper units
- Minute counter 15 min to infinity
- Contamination drawer
- Indication of operation and heating
- The option of selecting the extraction grids, pliers or combination of the two



TO 920 GH



TO 930 GH



TO 940 GH



TO 960 GH

Index	Model	mm	kg	V / Hz	kW	Grid / holder
101 600 552	TO 920 GH	348 x 274 x 288	7,4	230 / 50-60	1,6	1 / 2
101 600 562	TO 930 GH	453 x 274 x 288	8,8	230 / 50-60	2	1 / 3
101 600 572	TO 940 GH	375 x 274 x 403	9,8	230 / 50-60	2,4	2 / 4
101 600 582	TO 960 GH	452 x 274 x 403	11,7	230 / 50-60	3	2 / 6

TO 920

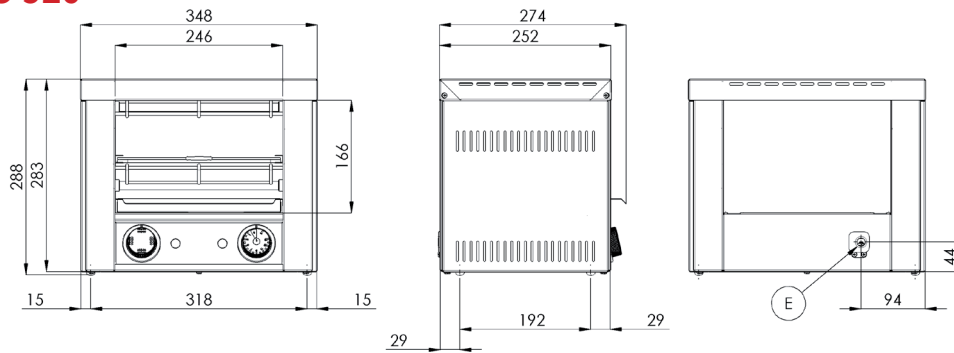

TO 930

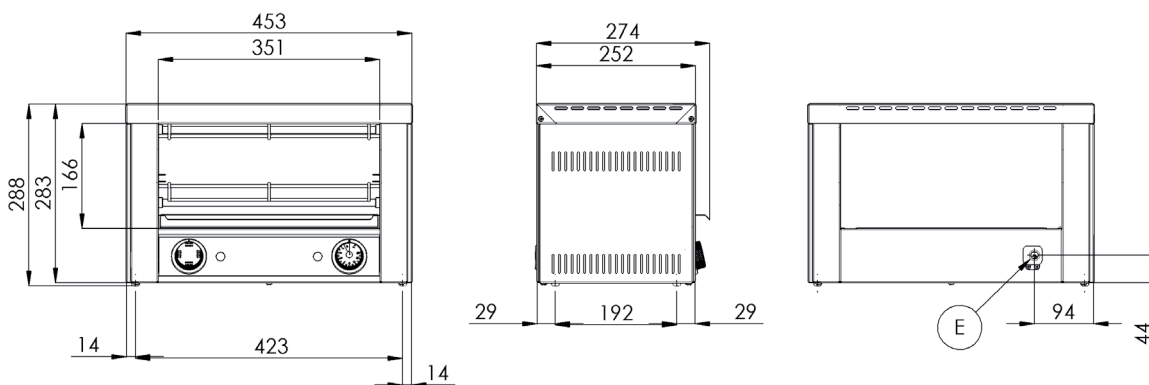

TO 940

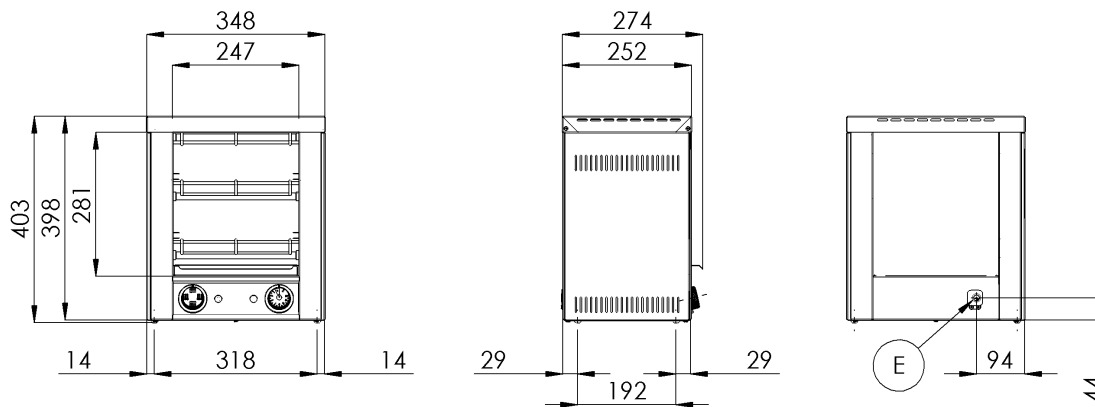

TO 960

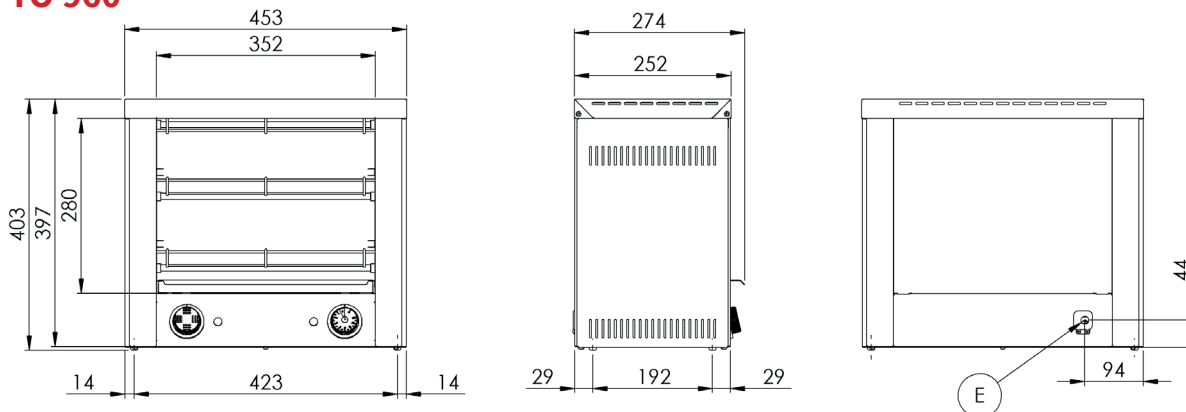

E - electric